

LINOVISION

POE-EXT6002GP

User Manual

Updated on September 14, 2023

Package Contents

Check the following contents of your package:

- PoE Extender x 1
- User Guide x 1
- Wrench x 1
- Accessories (water joint)

If any part is lost and damaged, please contact your local agent immediately.

Introduction

This Product is a Gigabit IP67 waterproof PoE extender independently developed by our company. It supports one RJ45 (PD) port in and 90W input(IEEE802.3bt). Two ports have PSE function, each supporting up to 30W output, without configuration, plug and play.

Professional room shell design, adapted to various harsh environments, with high stability, reliability, industrial level, wide temperature. The whole machine does not need power adapter, so it is convenient for harsh outdoor environment . reliable power for outdoor work AP, cameras etc.

Hardware Description

Front Panel

The front panel composed by PSE output port , input port and relevant indicator, as shown below:

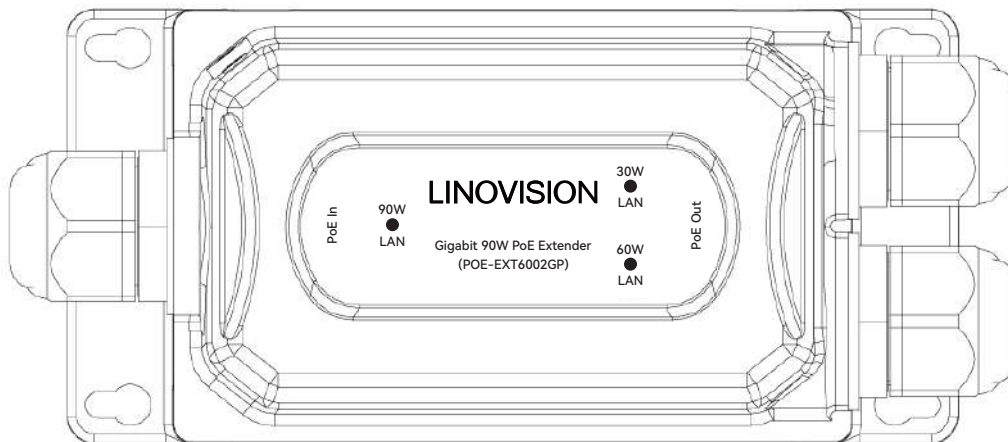

LED indicator

LED	Color	Function
LAN	Green	Off: No device is connected to the corresponding port Light: Indicates the link through that port is successfully established at 10/100/1000Mbps. Blink: transmitting data and power

Left Panel

Schematic diagram of left panel: input port (PoE In) and grounding column, Standard network Cate5 cable (line diameter 5.5mm).

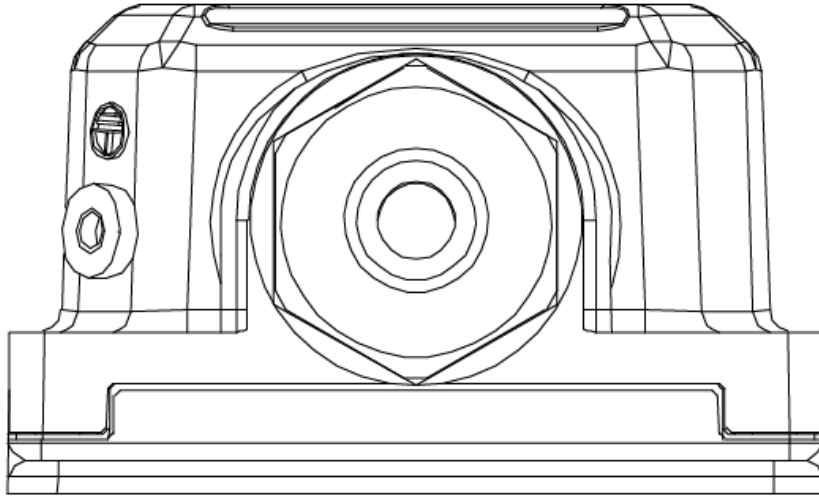

Right Panel

Schematic diagram of right panel: the output port (PoE out) requires the use of standard network cate5 cable (Line diameter 5.5mm).

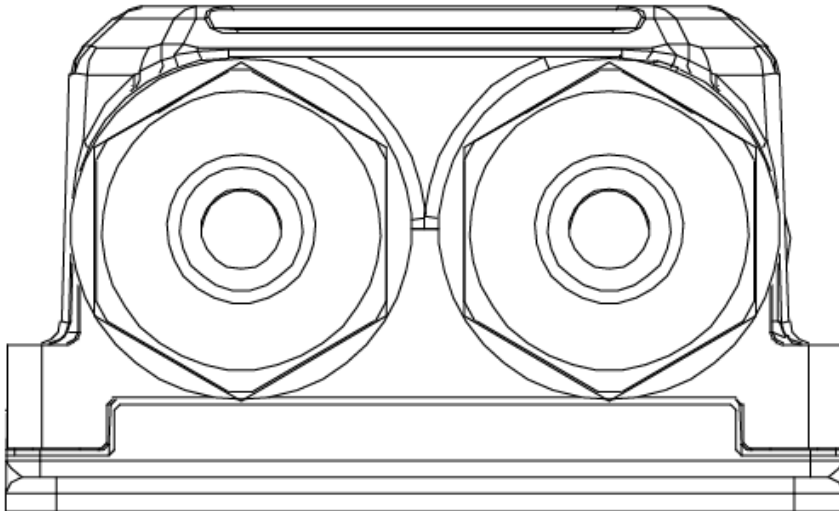

Installation

This part describes how to install your machine and make connections to it. Please follow the following instructions in avoid of incorrect installation causing device damage and security threat.

- The nuts of the waterproof joint should be tightened in full fit with the joint's thread and fit to the hexagon plane, otherwise it is easy to get water and damage the machine;
- Do not place the machine on an unstable case or desk. The machine might be damaged severely in case of a fall;
- Make sure that the operating voltage is the same one labeled on the machine;
- Do not open the chassis while the machine is operating or when electrical hazards are present to avoid electrical shocks.

Desktop Installation

Install the machine on a desktop, place the machine carefully on the counter, the bottom is as follows:

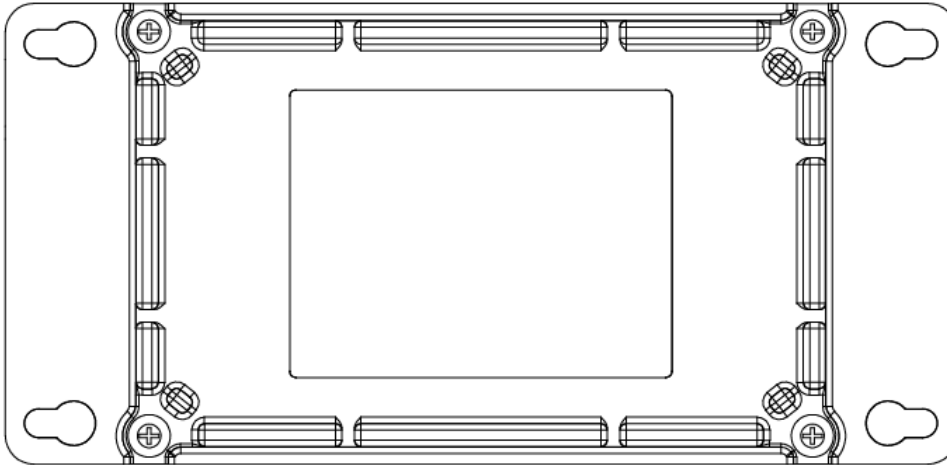

Wall-mounted installation

Please follow these steps to install the machine:

First fix the four screws on the wall (screw cap diameter recommended 5.5-6.5mm) and turn the machine upside down.

Align the four fixing holes of the machine as shown below and hang the machine smoothly on the screws.

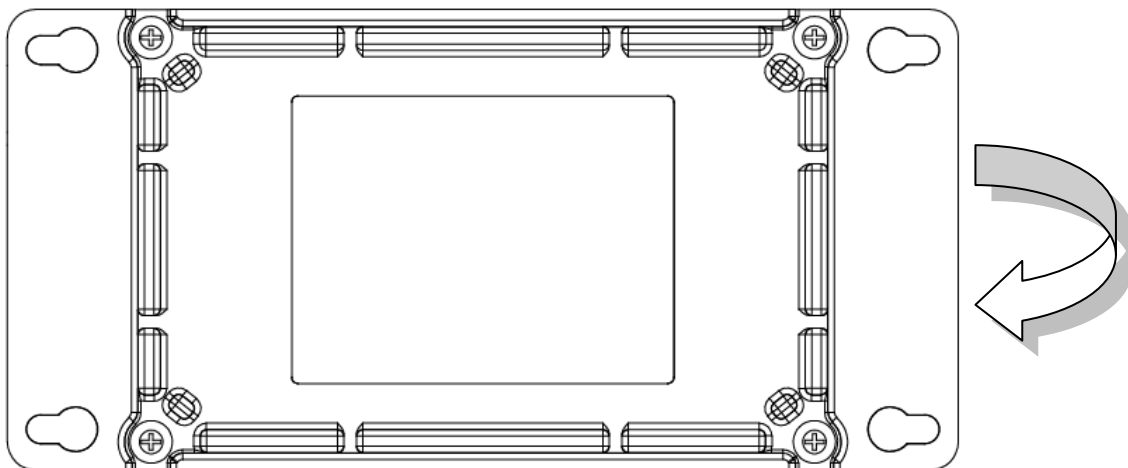

Application diagram of PoE injector:

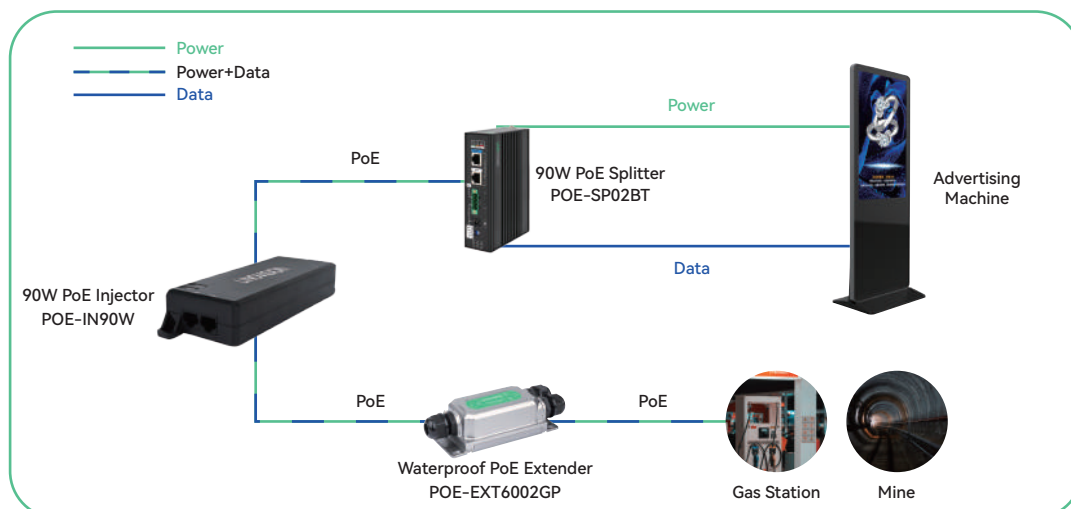

Specifications

Model	2-port Gigabit waterproof PoE Extender
Port	PoE in port:1 x 10/100/1000Mbps RJ45 port PoE out port : 2 x 10/100/1000Mbps RJ45 port
Standard	IEEE802.3, IEEE802.3u, IEEE802.3ab, IEEE802.3af, IEEE802.3at, IEEE802.3bt, IEEE802.3x
Network Media(Cable)	10BASE-T: UTP category 3,4,5 cable (≤100m) 100BASE-TX: UTP category 5 cable (≤100m) 1000BASE-T: UTP category 5e cable (≤100m)
Dimensions (L*W*H)	150*73*44MM
PoE input	90W Max
PoE power output	48-55V DC Port1:30W Max Port2:60W Max
PSE Power on RJ-45	Anode3/6 Cathode1/2 Anode4/5 Cathode7/8
Temperature	Operating Temperature: -20° C ~ 60 ° C Storage Temperature: -40 ° C ~ 80 ° C
Humidity	Operating Humidity: 10% ~ 90% non-condensing Storage Humidity: 5% ~ 90% non-condensing
Waterproof rate	IP67
Hazardous rating	IK10